

ArrowFlow™ Series Air Conveyors

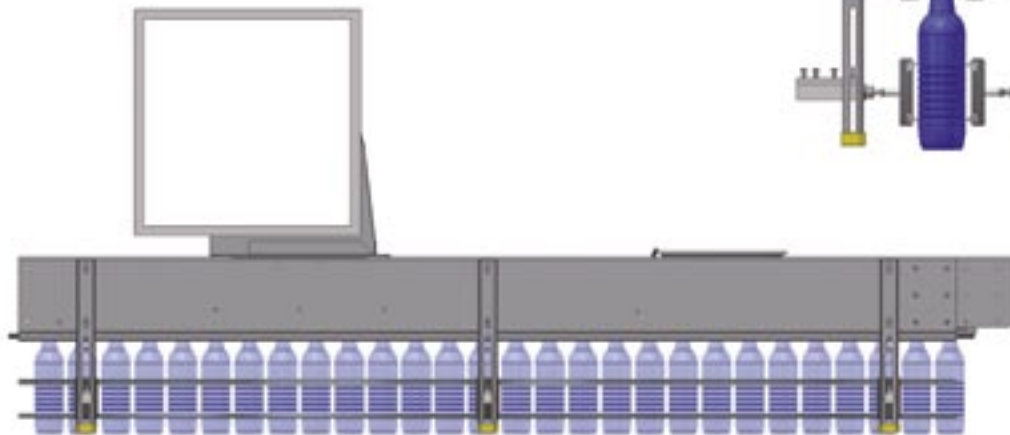

Products

- Air conveyors for empty PET bottles.
- Aseptic air conveyors for empty PET bottles.
- Empty PET bottle accumulation.
- Air cushion conveyors for empty cartons and boxes.
- Air cushion conveyors for plastic cap handling.
- Vacuum conveyors for empty cans and boxes.
- Ionized air rinsers for empty cans.
- Mass air deck conveyor for empty steel and aluminum cans.
- Vacuum conveyors for empty can inspectors.

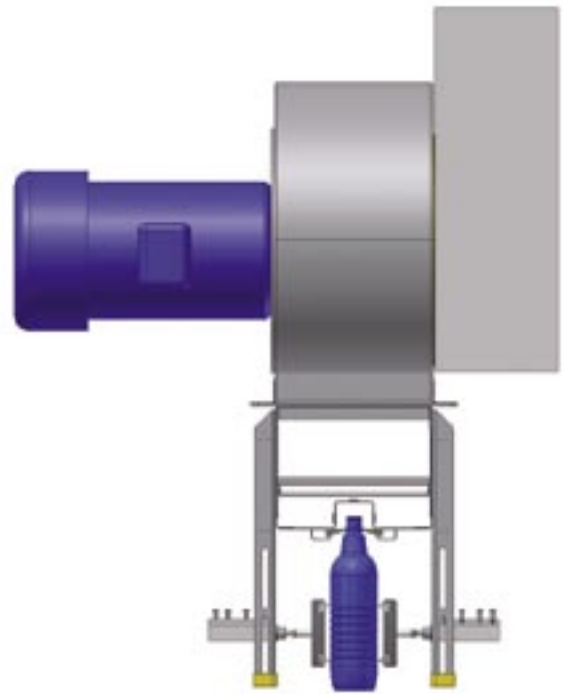
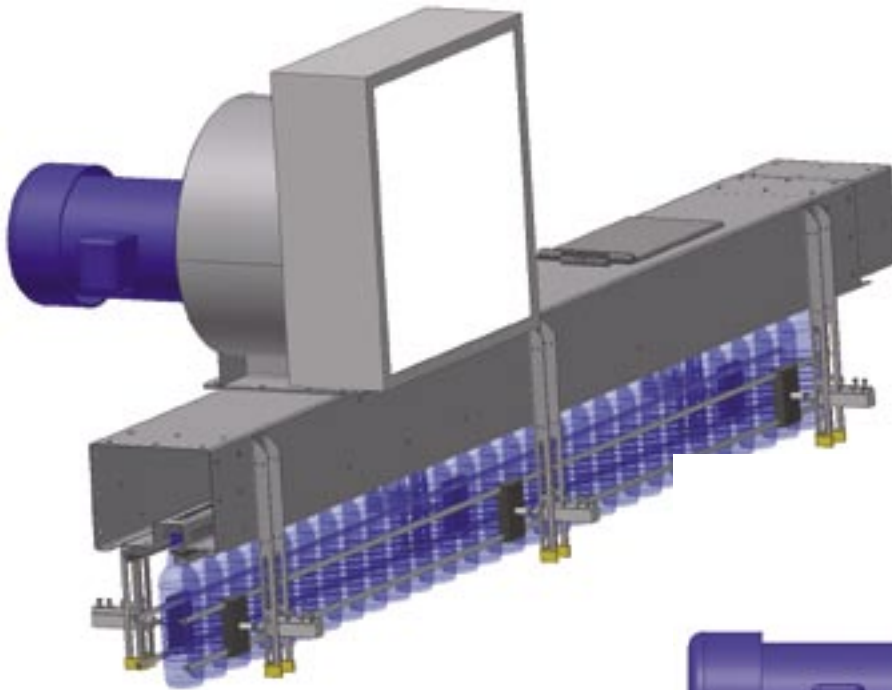

Features and Benefits

- Heavy duty high quality construction (stainless steel or mild steel).
- Over 125 years combined engineering experience.
- Complete in house testing on all control panels.
- Options for any control package:
 - Allen Bradley
 - Siemens
 - Danfoss
 - Mitsubishi
 - Omron
 - Modicon
 - Other
- Optional unique 4-pressure VFD controlled system offering maximum product control.
- Available fixed, adjustable, or automatic multi-position neck and body guides.
- Optimum transition to and from table-top sections with parallel hinged sections.
- Vertical air elevators and lowerators.
- Modular divert, merge and laning units:
 - Multiple lane divert units 2 to 1, 3 to 1 and 4 to 1
 - Multiple lane merge units 1 to 2, 3 or 4 lanes
 - Multiple lane switch units for 2 to 2
 - Motor driven switching with encoder feedback to ensure positioning within +/- 0.1mm
 - Dual stops to prevent product jam during gate shifting

