

# ArrowSummit™ Series Mat Top Conveyors

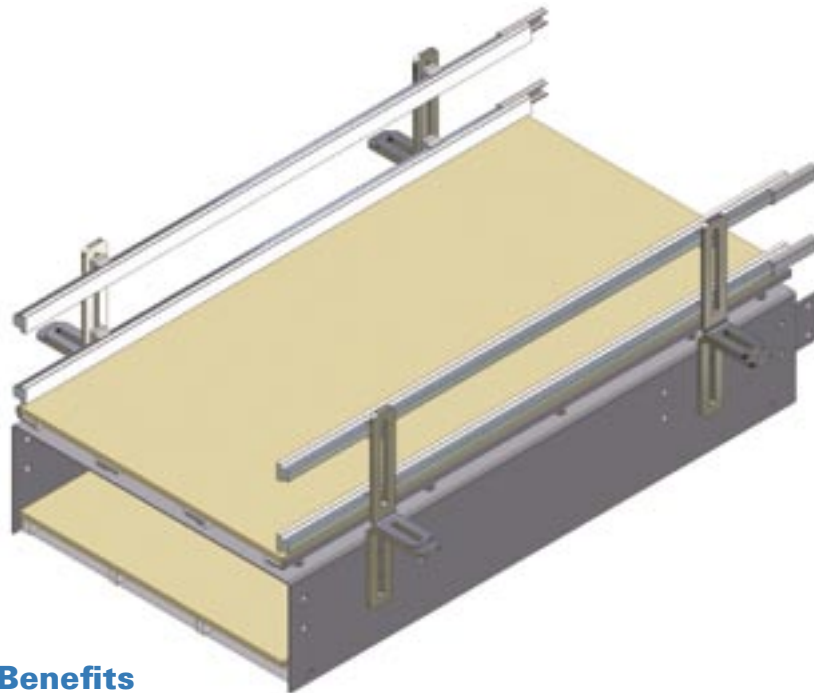
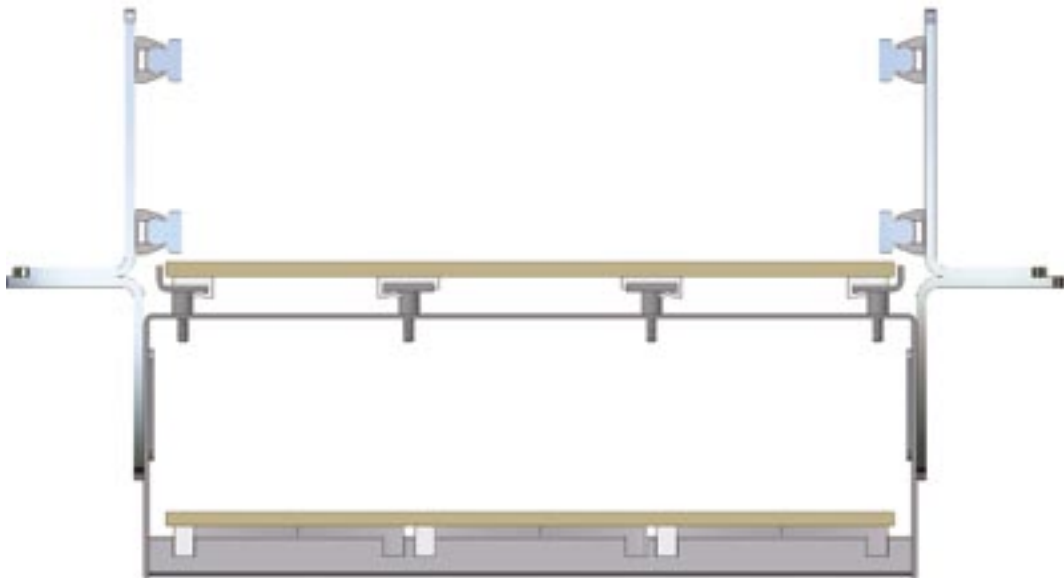

## Features and Benefits

- Closed Top construction.
- Heavy-duty stainless steel or painted mild steel construction.
- Bolt together design with use of vibration resistant fasteners.
- Compatible with industry standard modular plastic belts offering a continuous conveying surface.
- UHMW clip-on wearstrips and roller or slider return.
- Full array of complimentary accessories - guide rails, brackets (fixed and adjustable), product gating (powered and manual), dust covers, drip pans, supports and transfer aids.
- Complete array of modular sections - dynamic transfer section, parallel side transfers, Pressureless Singlefilers, deceleration modules, drive end, idle end and incline/decline modules.