

ArrowSummit™ Series Table Top Conveyors

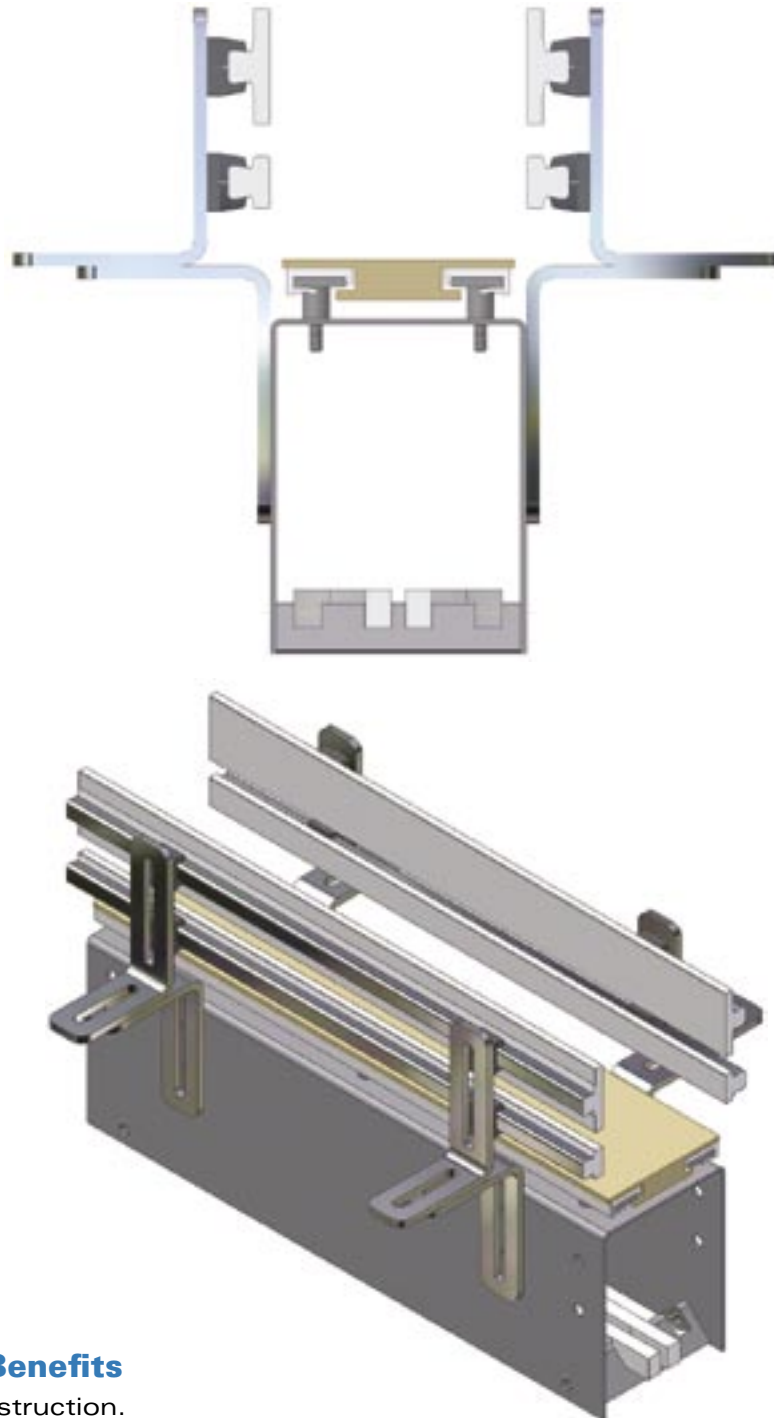

Features and Benefits

- Closed Top construction.
- Heavy-duty stainless steel or painted mild steel construction.
- Bolt together design with use of vibration resistant fasteners.
- Compatible with industry standard table top flight chains.
- UHMW clip-on wearstrips and roller or slider return.
- Full array of complimentary accessories - guide rails, brackets (fixed and adjustable), product gating (powered and manual), dust covers, drip pans, supports and transfer aids.
- Complete selection of modular sections - flex curves, dynamic transfer section, parallel side transfers, combiners, drive end, idle end and incline/decline modules.